

NAME: LED Corn Light

P/N: PGL-612XX

Advantages

- UL, cUL certificate
- G24D/GX24D (2 PIN)
G24Q/GX24Q (4 PIN) lamp base
- Warm/Natural/Cool/Cold white
- 360 degree lighting, high CRI
- IP64 Waterproof Rating
- Big heat sink
- Can be with frosted cover
- Compatible with magnetic ballast
- Internal driver, input voltage 100-277V AC
- No UV or IR in the beam
- Easy to install and operate
- Energy saving, long service life
- Light is soft and uniform, safe to eyes
- Instant start, NO flickering, NO humming
- Green and eco-friendly without mercury

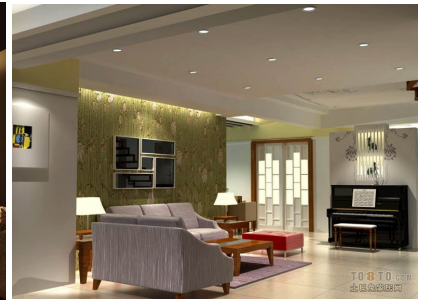

Applications

Widely used in supermarket, warehouse, garage, home, office, hotel, hospital, school, street, garden etc.

PRODUCT SPECIFICATIONS	
Product name	LED Corn Light
Part No	PGL-612XX
Light Type	Corn Light
Dimension	45mm dia x 58mm
Technical Characteristics	
Color temperature	2700-7000K
CRI	> 70
Lumen	1140-1320 lm
Lumen Efficacy	95-110 lm/W
Input Power	12 W
Viewing Angle	360 degree
Input Voltage	100-277V AC 50/60Hz
PFC	>90%
Equivalent	100W incandescent/30W CFL
Waterproof Rating	IP64
MATERIALS	
LED Brand	EPISTAR
LED Type	SMD2835
LED QTY	98 PCS
Housing	PC+AL
Housing color	White
Cover	Clear PC
OTHER	
Operating Temperature	-4°F to +113°F (-20°C to +45°C)
Operating Humidity	20%-70% RH
Storage Temperature	-22°F to +176°F (-30°C to +80°C)
Storage Humidity	10%-75% RH
Application	Indoor
Safety Certification	UL, cUL,
Warranty Time	5 Years

DATA OF LAMP		PHOTOMETRIC DATA Eff: 113.56 lm/W			
MODEL		Imax (cd)	149.9	S/MH (C0/180)	2.23
NOMINAL POWER (W)	12	LOR (%)	117.2	S/MH (C90/270)	2.52
RATED VOLTAGE (V)	230	TOTAL FLUX (lm)	1322.1	η UP, DN (C0-180)	24.8, 33.4
NOMINAL FLUX (lm)	1128.01	CIE CLASS	DIFFUSE	η UP, DN (C180-360)	24.7, 34.3
LAMPS INSIDE	1	η up (%)	49.5	CIBSE SHR NOM	2.00
TEST VOLTAGE (V)	230	η down (%)	67.8	CIBSE SHR MAX	0.00

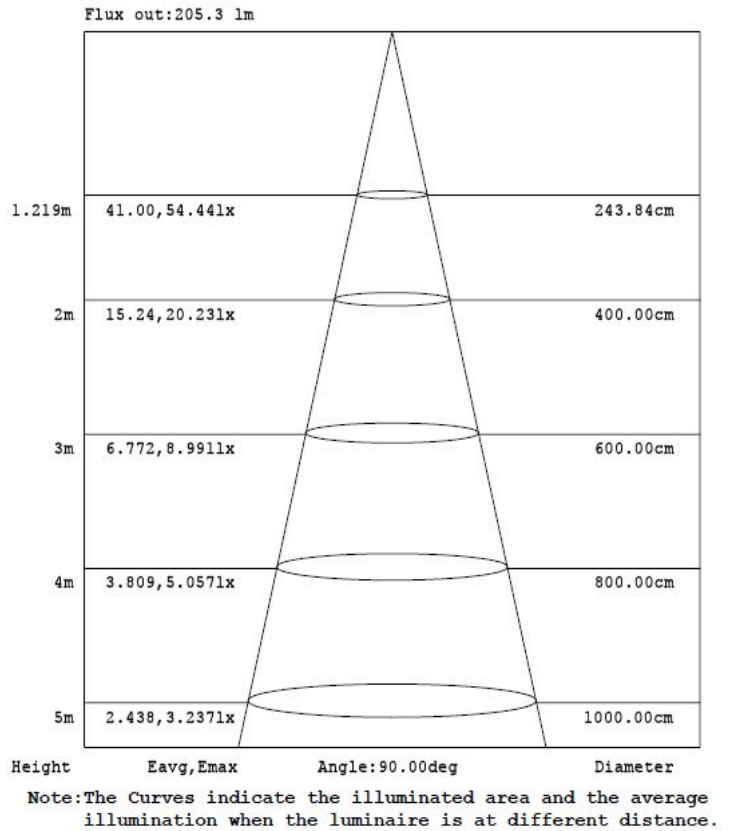
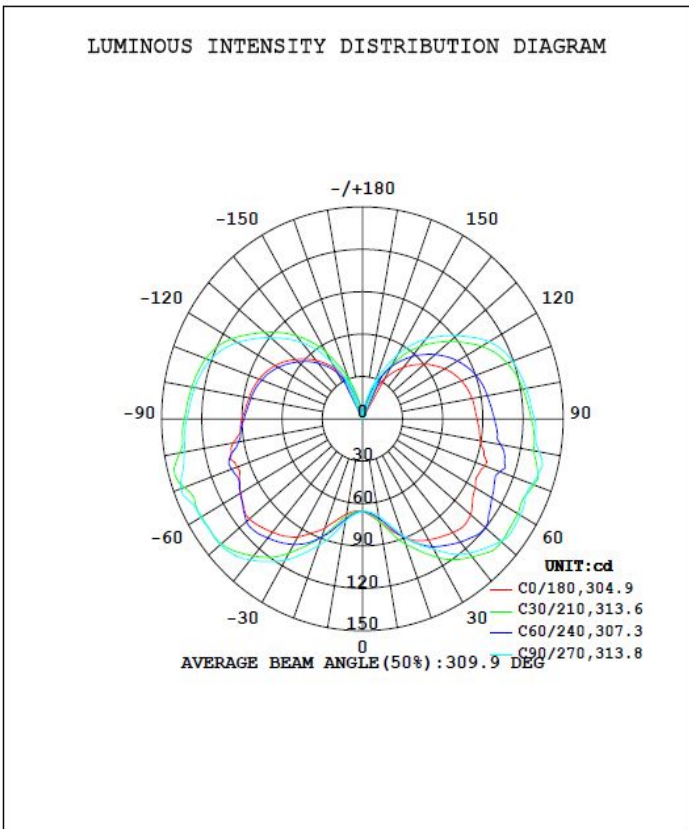

Package

LED Corn Light

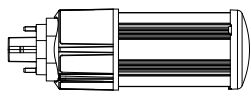

Into EPE bag

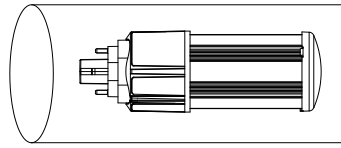

Into inner box

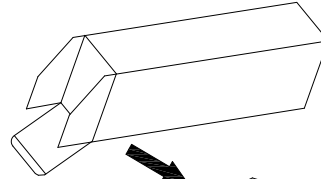

Joint sealing

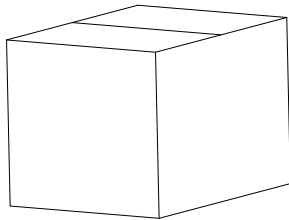

Into outer box

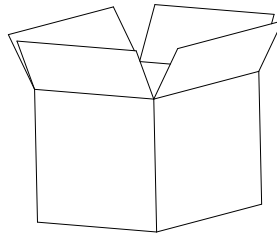

Into EPE

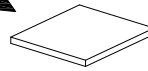

Cover inner box

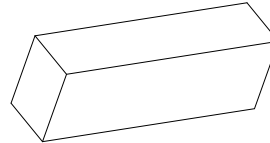

	Size	Qty/ Carton	Net Weight/ Carton	Gross Weight/ Carton
Inner box	6.5" x 1.8" x 1.8"	1	0.35 lbs	0.48 lbs
Outer box	13.8" x 9.8" x 9.8"	50	17.6 lbs	26.9 lbs

Notice For User

- Turn off power before installing or changing assembly parts.
- The input voltage and lamps should be matched, after connecting the power line, make sure the wiring section is insulated.
- Make sure to remove or bypass the electronic ballast in the fixtures before installing the lamps.
- Suitable for damp locations. Do not use with dimmers.
- Suitable for use in enclosed luminaires, min. lamp compartment dimensions: 12.2" x 7.5" x 7.5".
- Only qualified personnel should install, do not disassemble the lamp.

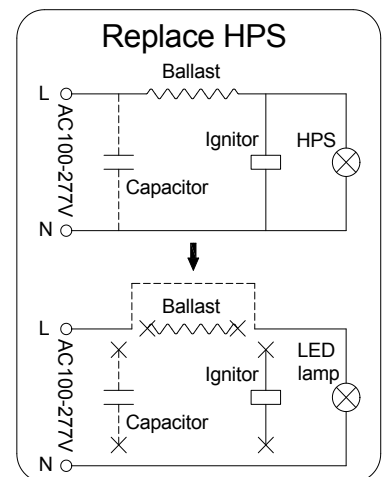
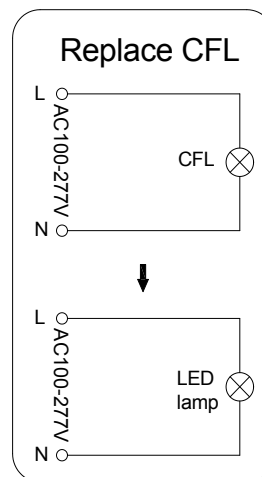

Troubleshooting

Problem	Check points
Flickering of the lamp	Turn off the power and turn on again in 3 minutes. If same phenomena occurs, call a technician
Not working	Check the connections